

XFP-10G-ER-PLU

10Gb/s 40km XFP Optical Transceiver

PRODUCT FEATURES

- Hot-pluggable XFP footprint
- Supports 9.95Gb/s to 11.3Gb/s bit rates
- Supports Lineside and XFI loopback
- RoHS-6 Compliant (lead-free)
- Power dissipation <3.5W
- Case temperature range:0°C to 70°C
- Maximum link length of 40km
- Cooled 1550nm EML and PIN receiver
- Full Duplex LC connector
- No Reference Clock required
- Built-in digital diagnostic functions
- Standard bail release mechanism

APPLICATIONS

- 10GBASE-ER/EW 10G Ethernet
- 40KM 10G Fiber Channel
- SONET OC-192 &SDH STM 64

*This spec sheet is also for other vendor compatible units with the last 3 digits of the part number varying based on vendor code. Please see the last page of this specification sheet for a list of vendor codes

PRODUCT DESCRIPTION

PLUSOPTIC's XFP-10G-ER-PLU Small Form Factor 10 G (XFP) transceivers are compliant with the current XFP Multi-Source Agreement (MSA) Specification. They comply with 10-Gigabit Ethernet 10GBASE-ER/EW per IEEE 802.3ae and 10G Fiber Channel 40KM. Digital diagnostics functions are available via a 2-wire serial interface, as specified in the XFP MSA. The transceiver is RoHS compliant and leads free per Directive 2002/95/EC³.

I . Absolute Maximum Ratings

Parameter	Symbol	Min	Typ	Max	Unit	NOTE
Maximum Supply Voltage 1	Vcc3	-0.5		4.0	V	
Maximum Supply Voltage 2	Vcc5	-0.5		6.0	V	
Storage Temperature	T _s	-40		85	°C	
Case Operating Temperature	T _{case}	0		70	°C	

II . Electrical Characteristics

Parameter	Symbol	Min	Typ	Max	Unit	NOTE
Main Supply Voltage	Vcc5	4.75		5.25	V	
Supply Voltage #2	Vcc3	3.13		3.45	V	
Supply Current – Vcc5 supply	Icc5			320	mA	
Supply Current – Vcc3 supply	Icc3			450	mA	
Module total power	P			3.5	W	1
Transmitter						
Input differential impedance	R _{in}		100		Ω	2
Differential data input swing	V _{in,pp}	120		820	mV	
Transmit Disable Voltage	V _D	2.0		Vcc	V	3
Transmit Enable Voltage	V _{EN}	GND		GND+ 0.8	V	
Transmit Disable Assert Time				10	us	
Receiver						
Differential data output swing	V _{out,pp}	340	650	850	mV	4
Data output rise time	t _r			38	ps	5
Data output fall time	t _f			38	ps	5
LOS Fault	V _{LOS fault}	Vcc – 0.5		Vcc _{HOST}	V	6
LOS Normal	V _{LOS norm}	GND		GND+0.5	V	6
Power Supply Rejection	PSR		See Note 6 below			7

Notes:

- Notes: Maximum total power value is specified across the full temperature and voltage range.
- After internal AC coupling.
- Or open circuit.
- Into 100 ohms differential termination.
- These are unfiltered 20-80% values
- Loss Of Signal is open collector to be pulled up with a 4.7k – 10kohm resistor to 3.15 – 3.6V. Logic 0 indicates normal operation; logic 1 indicates no signal detected.
- Per Section 2.7.1. in the XFP MSA Specification1.

III. Optical Characteristics

Parameter	Symbol	Min	Typ	Max	Unit	NOTE
Transmitter						
Average Optical Power	P _{out}	-1		4	dBm	
Optical Wavelength	λ	1530		1570	nm	
Side mode Suppression ratio	SMSR	30			dB	
Optical Extinction Ratio	ER	8.2			dB	
Transmitter and Dispersion Penalty	TDP			2	dB	
Average Launch power of OFF transmitter	P _{OFF}			-30	dBm	
Tx Jitter	Tx _j	Compliant with 802.3ae requirements				
Receiver						
Receiver Sensitivity	R _{SENS}			-16.5	dBm	1
Input Saturation Power (Overload)	P _{sat}	+0.5			dBm	
Wavelength Range	λ _C	1270		1610	nm	
Receiver Reflectance	R _{rx}			-27	dB	
LOS De-Assert	LOS _D			-18	dBm	
LOS Assert	LOS _A	-32			dBm	
LOS Hysteresis		0.5			dB	

Notes:

1. Measured with BER < 10⁻¹² @ 10.3Gbps, 2³¹ – 1 PRBS.

IV. Pin Assignment

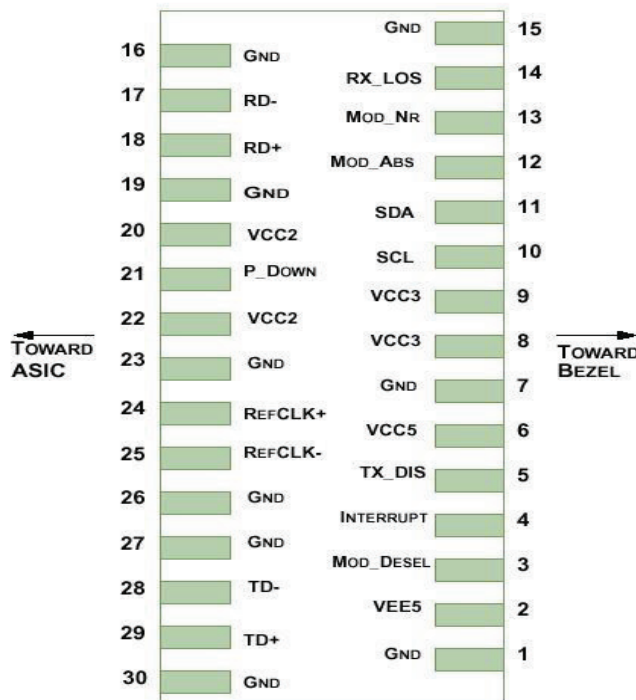

Diagram of Host Board Connector Block Pin Numbers and Name

Pin	Logic	Symbol	Name/Description	NOTE
1		GND	Module Ground	1
2		VEE5	Optional -5.2 Power Supply – Not required	
3	LVTTL-I	Mod-Desel	Module De-select; When held low allows the module to respond to 2-wire serial interface commands	
4	LVTTL-O	Interrupt	Interrupt (bar); Indicates presence of an important condition which can be read over the serial 2-wire interface	2
5	LVTTL-I	TX_DIS	Transmitter Disable; Transmitter laser source turned off	
6		VCC5	+5 Power Supply	
7		GND	Module Ground	1
8		VCC3	+3.3V Power Supply	
9		VCC3	+3.3V Power Supply	
10	LVTTL-I	SCL	Serial 2-wire interface clock	2
11	LVTTLI/O	SDA	Serial 2-wire interface data line	2
12	LVTTL-O	Mod_Abs	Module Absent; Indicates module is not present. Grounded in the module.	2
13	LVTTL-O	Mod_NR	Module Not Ready; PLUSOPTIC defines it as a logical OR between RX_LOS and Loss of Lock in TX/RX.	2
14	LVTTL-O	RX_LOS	Receiver Loss of Signal indicator	2
15		GND	Module Ground	1
16		GND	Module Ground	1
17	CML-O	RD-	Receiver inverted data output	
18	CML-O	RD+	Receiver non-inverted data output	
19		GND	Module Ground	1
20		VCC2	+1.8V Power Supply – Not required	
21	LVTTL-I	P_Down/RST	Power Down; When high, places the module in the low power stand-by mode and on the falling edge of P_Down initiates a module reset	
			Reset; The falling edge initiates a complete reset of the module including the 2-wire serial interface, equivalent to a power cycle.	
22		VCC2	+1.8V Power Supply – Not required	
23		GND	Module Ground	1
24	PECL-I	RefCLK+	Reference Clock non-inverted input, AC coupled on the host board – Not required	3
25	PECL-I	RefCLK-	Reference Clock inverted input, AC coupled on the host board – Not required	3
26		GND	Module Ground	1
27		GND	Module Ground	1
28	CML-I	TD-	Transmitter inverted data input	
29	CML-I	TD+	Transmitter non-inverted data input	
30		GND	Module Ground	1

Notes:

1. Module circuit ground is isolated from module chassis ground within the module.
2. Open collector; should be pulled up with 4.7k – 10kohms on host board to a voltage between 3.15V and 3.6V.
3. A Reference Clock input is not required by the XFP-10G-ER-PLU. If present, it will be ignored.

V. General Specifications

Parameter	Symbol	Min	Typ	Max	Units	NOTE
Bit Rate	BR	9.95		11.3	Gb/s	1
Bit Error Ratio	BER			10 ⁻¹²		2
Max. Supported Link Length	L _{MAX}			40	km	1

Notes:

- 10GBASE-ER/EW.
- Tested with 10.3Gbps, 2³¹ – 1 PRBS

VI. Digital Diagnostic Functions

As defined by the XFP MSA, PLUSOPTIC XFP transceivers provide digital diagnostic functions via a 2-wire serial interface, which allows real-time access to the following operating parameters:

- Transceiver temperature
- Laser bias current
- Transmitted optical power
- Received optical power
- Transceiver supply voltage

It also provides a sophisticated system of alarm and warning flags, which may be used to alert end-users when particular operating parameters are outside of a factory-set normal range.

The operating and diagnostics information is monitored and reported by a Digital Diagnostics Transceiver Controller (DDTC) inside the transceiver, which is accessed through the 2-wire serial interface. When the serial protocol is activated, the serial clock signal (SCL pin) is generated by the host. The positive edge clocks data into the XFP transceiver into those segments of its memory map that are not write-protected. The negative edge clocks data from the XFP transceiver. The serial data signal (SDA pin) is bi-directional for serial data transfer. The host uses SDA in conjunction with SCL to mark the start and end of serial protocol activation. The memories are organized as a series of 8-bit data words that can be addressed individually or sequentially. The 2-wire serial interface provides sequential or random access to the 8 bit parameters, addressed from 000h to the maximum address of the memory.

For more detailed information, including memory map definitions, please see the XFP MSA Specification.

VII. Mechanical Specifications

PLUSOPTIC's XFP transceivers are compliant with the dimensions defined by the XFP Multi-Sourcing Agreement (MSA).

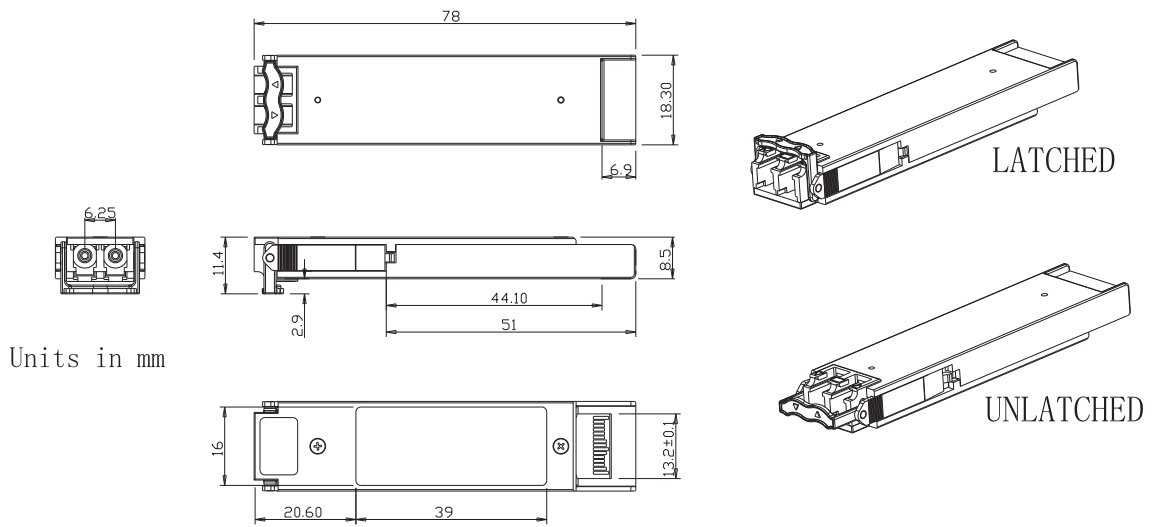

XFP Transceiver (dimensions are in mm)

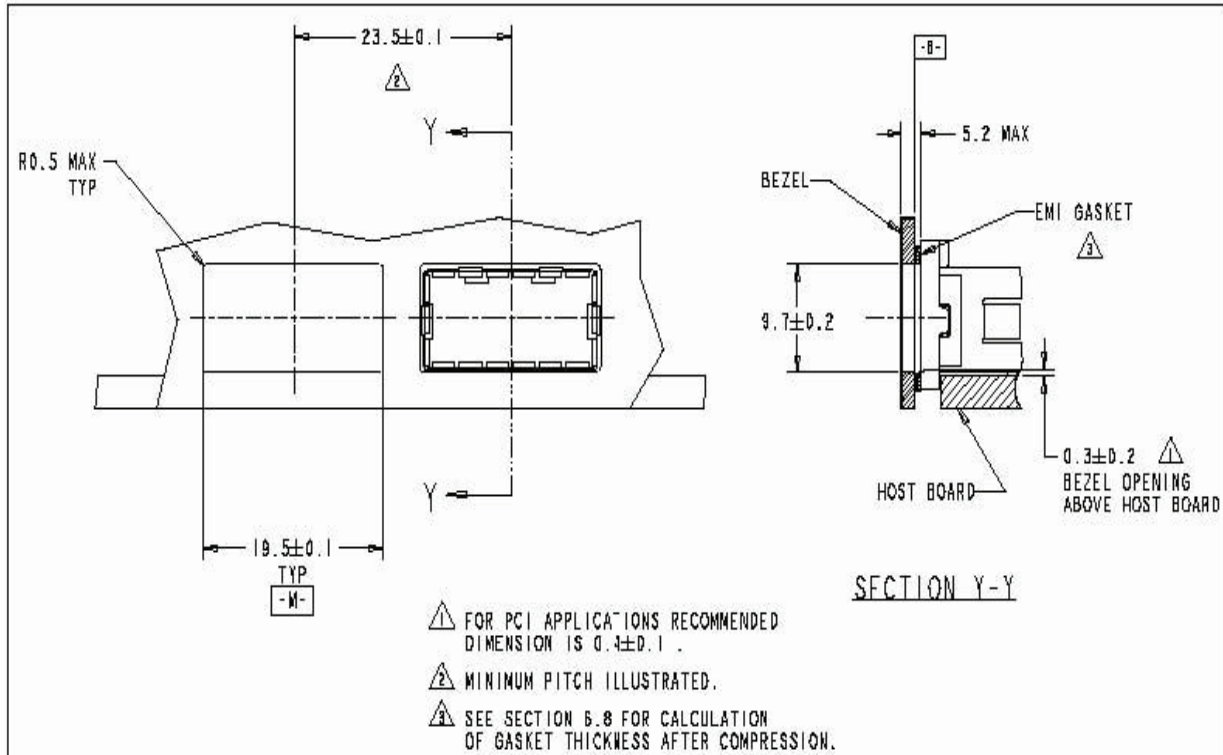

IX. Regulatory Compliance

Feature	Reference	Performance
Electrostatic discharge (ESD)	IEC/EN 61000-4-2	Compatible with standards
Electromagnetic Interference (EMI)	FCC Part 15 Class B EN 55022 Class B (CISPR 22A)	Compatible with standards
Laser Eye Safety	FDA 21CFR 1040.10, 1040.11 IEC/EN 60825-1, 2	Class 1 laser product
Component Recognition	IEC/EN 60950, UL	Compatible with standards
ROHS	2002/95/EC	Compatible with standards
EMC	EN61000-3	Compatible with standards

X. Ordering Information

When ordering, to choose the vendor you require such as Cisco, HP, Juniper etc you need to replace the 'XXX' at the end of each SKU with the relevant 3 digit vendor code, for instance if you wanted a Cisco Multimode 1.25Gb SFP then the SKU would read SFP-1G-SX-CIS.

VENDOR	CODE	VENDOR	CODE	VENDOR	CODE	VENDOR	CODE
3com	3CO	Cyan	CYN	Huawei	HUA	PlusOptic	PLU
Adtran	ADT	Compaq	COM	IBM	IBM	Q-logic	QLO
Alcatel-Lucent	ALC	Dell	DEL	Intel	INT	QNA	QNA
Allied Telesis	ATE	Delta	DTA	JDS Uniphase	JDS	RAD	RAD
Allnet	ALL	D-LINK	DLI	Juniper	JUN	Redback	RED
Arista Networks	ARI	EMC	EMC	LNV	LNV	Riverstone	RIV
Aruba Networks	ARU	EMU	EMU	Linksys	LIN	Silicom	SIL
Asante	ASA	Enterasys	ENT	Marconi	MAR	Smartoptic	SMO
Avago	AVA	Extreme	EXT	McAfee	McA	SMC	SMC
Avaya	AVY	F5 Networks	F5	Meraki	MER	Solarflare	SLF
Black Box	BLK	Finisar	FIN	Milan Techn	MIL	Sun	SUN
Blade	BLA	Fluke	FLU	Moxa	MOX	SuperMicro	SUP
Bluecoat	BLU	Force 10	F10	NetAPP	NAP	Telco	TEL
Broadcom	BRD	Fortinet	FOR	Netgear	NET	TP-Link	TPL
Brocade	BRO	Foundry	FOU	Nortel	NOR	Transition	TRA
Calix	CAL	Fujitsu	FUJ	Packeteer	PKT	Trendnet	TRE
Ceragon Networks	CRN	Gigamon	GIG	PacketLight	PKL	Voltaire	VOL
Check Point	CHE	H3C	H3C	Palo Alto	PAL	WGD	WGD
CHL	CHL	HIR	HIR	Penguin	PEN	WES	WES
Ciena	CIE	HP	HP	Perle	PER	ZTE	ZTE
Cisco	CIS	HP ProCurve	HPP	PicoLight	PIC	ZYXEL	ZYX
Citrix	CIX	Huawei	HUA	Planet	PLA		